

EMC Test Report

Application No. : TB160312081
Applicant : EVEREXCEED INDUSTRIAL COMPANY LIMITED
Equipment Under Test (EUT)
EUT Name : Lithium Iron Phosphate Battery
Model No. : EV4850-T
Series Model No. : Please see the page of 3
Brand Name : EverExceed
Receipt Date : 2016-03-01
Test Date : 2016-03-01 to 2016-03-03
Issue Date : 2016-03-03
Standards : EN 61000-6-3:2007+A1:2011
EN 61000-6-1:2007
Conclusions : **PASS**

In the configuration tested, the EUT complied with the standards specified above
The EUT technically complies with the 2014/30/EU directive requirements

Test/Witness Engineer :

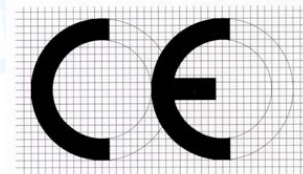
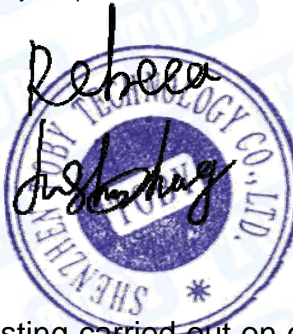

Approved & Authorized :

This report details the results of the testing carried out on one sample. The results contained in this test report do not relate to other samples of the same product. The manufacturer should ensure that all products in series production are in conformity with the product sample detailed in the report.

TABLE OF CONTENTS

1.	GENERAL INFORMATION.....	3
1.1.	Client Information	3
1.2.	General Description of EUT (Equipment Under Test).....	3
1.3.	Block Diagram Showing The Configuration of System Tested.....	3
1.4.	Description of Support Units.....	3
1.5.	Performance Criterion	4
1.6.	Test Facility	4
2.	TEST RESULTS SUMMARY	5
3.	TEST EQUIPMENT USED	6
4.	RADIATED EMISSION TEST	7
4.1.	Test Standard and Limit	7
4.2.	Test Setup	7
4.3.	Test Procedure	7
4.4.	Test Condition.....	8
4.5.	Test Data	8
5.	ELECTROSTATIC DISCHARGE IMMUNITY TEST	11
5.1.	Test Requirements.....	11
5.2.	Test Setup	11
5.3.	Test Procedure	12
5.4.	Test Data	12
6.	RADIATED ELECTROMAGNETIC FIELD IMMUNITY TEST	14
6.1.	Test Requirements.....	14
6.2.	Test Setup	14
6.3.	Test Procedure	14
6.4.	Test Data	15
7.	PHOTOGRAPHS - CONSTRUCTIONAL DETAILS	17
8.	PHOTOGRAPHS - TEST SETUP	19

1. General Information

1.1. Client Information

Applicant	:	EVEREXCEED INDUSTRIAL COMPANY LIMITED
Address	:	UNIT E, 3/F, GOOD HARVEST CENTRE, 33 ON CHUEN STREET, FANLING, NT., HONG KONG
Manufacturer	:	EVEREXCEED INDUSTRIAL COMPANY LIMITED
Address	:	UNIT E, 3/F, GOOD HARVEST CENTRE, 33 ON CHUEN STREET, FANLING, NT., HONG KONG

1.2. General Description of EUT (Equipment Under Test)

EUT Name	:	Lithium Iron Phosphate Battery
Model No.	:	EV4850-T
Series Model No.	:	EV48 XXX-T(XXX Stands for 5~200Ah), EP-48 XXX (XXX Stands for 5~200Ah), EP-24 XXX (XXX Stands for 5~200Ah), EP-12 XXX (XXX Stands for 5~200Ah), ES-48 XXX (XXX Stands for 5~200Ah), ES-24 XXX (XXX Stands for 5~200Ah), ES-12 XXX (XXX Stands for 5~200Ah)
Brand Name	:	EverExceed
Power supply	:	DC 48V
Remark: All above models are identical in schematic, structure and critical components except for different model number, color and different enclosure, therefore, EMC testing was performed with EV4850-T only.		

1.3. Block Diagram Showing The Configuration of System Tested

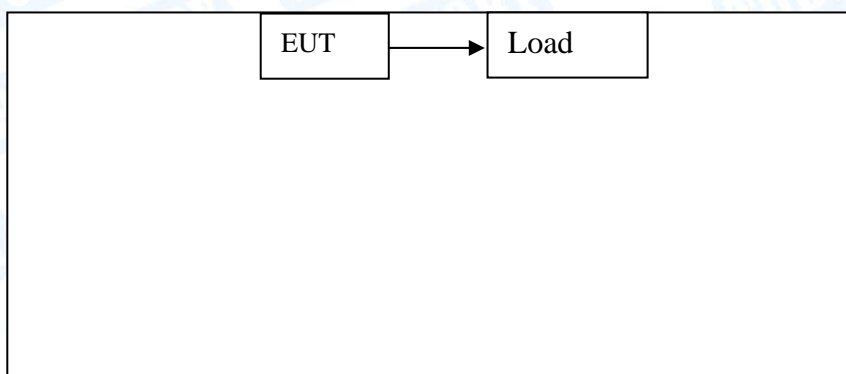

1.4. Description of Support Units

The EUT has been tested as an independent unit.

1.5. Performance Criterion

Criterion A: The equipment shall continue to operate as intended without operator intervention. No degradation of performance or loss of function is allowed below a performance level specified by the manufacturer when the equipment is used as intended.

Criterion B: After the test, the equipment shall continue to operate as intended without operator intervention. No degradation of performance or loss of function is allowed, after the application of the phenomena below a performance level specified by the manufacturer, when the equipment is used as intended.

Criterion C: Loss of function is allowed, provided the function is self-recoverable, or can be restored by the operation of the controls by the user in accordance with the manufacturer's instructions.

1.6. Test Facility

The testing report were performed by the Shenzhen Toby Technology Co., Ltd., in their facilities located at 1A/F., Bldg.6, Yusheng Industrial Zone, The National Road No.107 Xixiang Section 467, Xixiang, Bao'an, Shenzhen, Guangdong, China. At the time of testing, the following bodies accredited the Laboratory:

CNAS (L5813)

The Laboratory has been accredited by CNAS to ISO/IEC 17025: 2005 General Requirements for the Competence of Testing and Calibration Laboratories for the competence in the field of testing. And the Registration No.: CNAS L5813.

FCC List No.: (811562)

The Laboratory is listed in the United States of American Federal Communications Commission (FCC), and the registration number is 811562.

IC Registration No.: (11950A-1)

The Laboratory has been registered by Certification and Engineering Bureau of Industry Canada for radio equipment testing. The site registration: Site# 11950A-1.

2. TEST Results Summary

EMISSION		
Description of test items	Standards	Results
Conducted disturbance at mains terminals	EN 61000-6-3:2007+A1:2011	N/A
Radiated Disturbance	EN 61000-6-3:2007+A1:2011	Pass
Harmonic current emissions	EN 61000-3-2: 2014	N/A
Voltage fluctuation and flicker	EN 61000-3-3: 2013	N/A
IMMUNITY		
Description of test items	Standards	Results
Electrostatic Discharge (ESD)	EN 61000-4-2: 2009	Pass
Radio-frequency, Continuous radiated disturbance	EN 61000-4-3: 2006+A1: 2008 +A2:2010	Pass
EFT/B Immunity	EN 61000-4-4: 2012	N/A
Surge Immunity	EN 61000-4-5: 2014	N/A
Conducted RF Immunity	EN 61000-4-6: 2014	N/A
Power frequency magnetic field	EN 61000-4-8: 2010	N/A
Voltage dips, >95% reduction	EN 61000-4-11: 2004	N/A
Voltage dips, 30% reduction		
Voltage interruptions		
Note: N/A is an abbreviation for Not Applicable.		

3. Test Equipment Used

Radiation Emission Test					
Equipment	Manufacturer	Model No.	Serial No.	Last Cal.	Cal.Due Date
Spectrum Analyzer	Agilent	E4407B	MY45106456	Aug. 29, 2015	Aug. 28, 2016
EMI Test Receiver	Rohde & Schwarz	ESCI	101165	Aug. 07, 2015	Aug. 06, 2016
Bilog Antenna	ETS-LINDGREN	3142E	00117537	Mar.28, 2015	Mar. 27, 2016
Bilog Antenna	ETS-LINDGREN	3142E	00117542	Mar.28, 2015	Mar. 27, 2016
Horn Antenna	ETS-LINDGREN	3117	00143207	Mar.28, 2015	Mar. 27, 2016
Horn Antenna	ETS-LINDGREN	3117	00143209	Mar.28, 2015	Mar. 27, 2016
Pre-amplifier	HP	11909A	185903	Mar.28, 2015	Mar. 27, 2016
Pre-amplifier	HP	8447B	3008A00849	Mar.28, 2015	Mar. 27, 2016
Cable	HUBER+SUHNER	100	SUCOFLEX	Mar.28, 2015	Mar. 27, 2016
Signal Generator	Rohde & Schwarz	SML03	IKW682-054	Mar.28, 2015	Mar. 27, 2016
Positioning Controller	ETS-LINDGREN	2090	N/A	N/A	N/A
Discharge Immunity Test					
Equipment	Manufacturer	Model No.	Serial No.	Last Cal.	Cal.Due Date
ESD Generator	HAFELY	PESD 1610	H808671	Mar.20, 2015	Mar.19, 2016
Radiated Immunity Test					
Equipment	Manufacturer	Model No.	Serial No.	Last Cal.	Cal.Due Date
Signal Generator	Rohde & Schwarz	SMT03	200754	Mar.28, 2015	Mar. 27, 2016
Power Meter	Rohde & Schwarz	NRVD	110562	Feb. 16, 2016	Feb. 15, 2017
Voltage Probe	Rohde & Schwarz	URV5-Z2	12056	Feb. 16, 2016	Feb. 15, 2017
Voltage Probe	Rohde & Schwarz	URV5-Z2	12074	Feb. 16, 2016	Feb. 15, 2017
RF Amplifier	AR	50S1G4A	326720	Feb. 16, 2016	Feb. 15, 2017
Bilog Antenna	ETS	3142C	00047662	Feb. 16, 2016	Feb. 15, 2017
Horn Antenna	ARA	DRG-118A	16554	Feb. 16, 2016	Feb. 15, 2017

4. Radiated Emission Test

4.1. Test Standard and Limit

4.1.1. Test Standard

EN 61000-6-3:2007+A1:2011

4.1.2. Test Limit

Radiated Disturbance Test Limit

Frequency	Limit (dB μ V/m)
	Quasi-peak Level
30MHz~230MHz	40
230MHz~1000MHz	47

Remark: 1. The lower limit shall apply at the transition frequency.
2. The test distance is 3m.

4.2. Test Setup

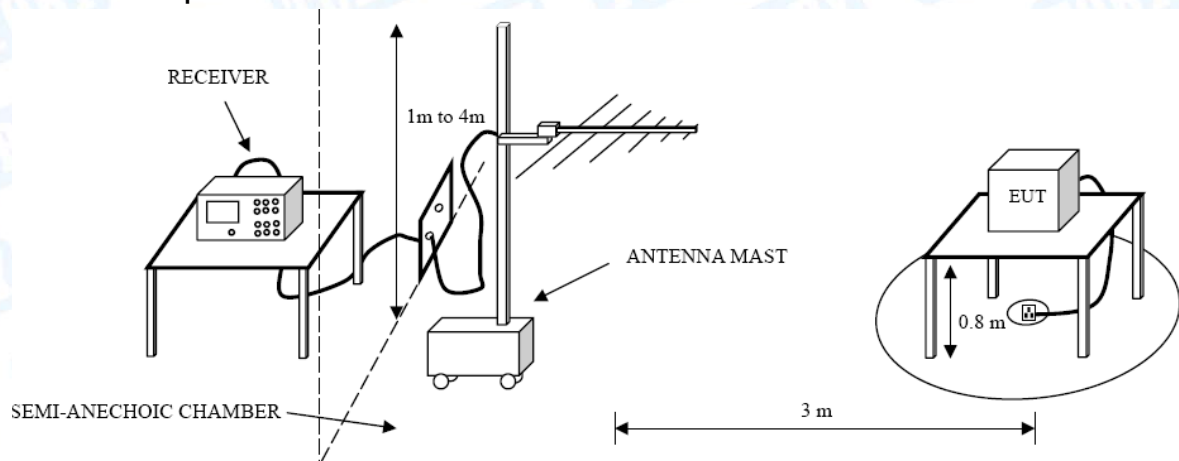

4.3. Test Procedure

The EUT was placed on the top of a rotating table 0.8 meters above the ground at a 3m. The table was rotated 360 degrees to determine the position of the highest radiation.

The height of the equipment or of the substitution antenna shall be 0.8 m; the height of the test antenna shall vary between 1 m to 4 m. Both horizontal and vertical polarizations of the antenna are set to make the measurement.

The initial step in collecting radiated emission data is a spectrum analyzer peak detector mode pre-scanning the measurement frequency range.

If the Peak Mode measured value compliance with and lower than Quasi Peak Mode Limit, the EUT shall be deemed to meet QP Limits and then no additional QP Mode measurement performed.

4.4. Test Condition

Temperature	:	23 °C
Relative Humidity	:	52 %
Pressure	:	1010 hPa
Test Power	:	DC 48V

4.5. Test Data

Please refer to the following pages.

EUT:	Lithium Iron Phosphate Battery	Model Name :	EV4850-T
Temperature:	25 °C	Relative Humidity:	55%
Test Voltage:	DC 48V		
Ant. Pol.	Horizontal		
Test Mode:	Normal Mode		
Remark:			

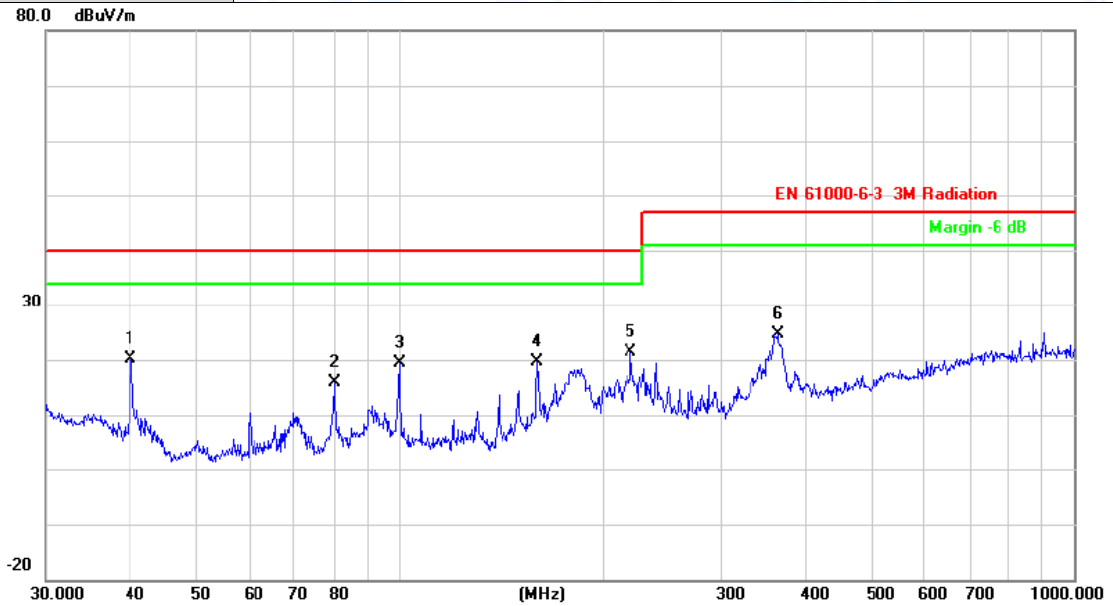

No.	Mk.	Freq. MHz	Reading Level dBuV	Correct Factor dB/m	Measure- ment dBuV/m	Limit dBuV/m	Over dB	Detector
1		39.9942	40.20	-20.16	20.04	40.00	-19.96	peak
2		80.0806	39.28	-23.28	16.00	40.00	-24.00	peak
3		100.2286	41.20	-21.82	19.38	40.00	-20.62	peak
4		160.3456	40.28	-20.53	19.75	40.00	-20.25	peak
5	*	220.6171	40.95	-19.50	21.45	40.00	-18.55	peak
6		364.2595	39.14	-14.52	24.62	47.00	-22.38	peak

Emission Level= Read Level+ Correct Factor

EUT:	Lithium Iron Phosphate Battery	Model Name :	EV4850-T
Temperature:	25 °C	Relative Humidity:	55%
Test Voltage:	DC 48V		
Ant. Pol.	Vertical		
Test Mode:	Normal Mode		
Remark:			

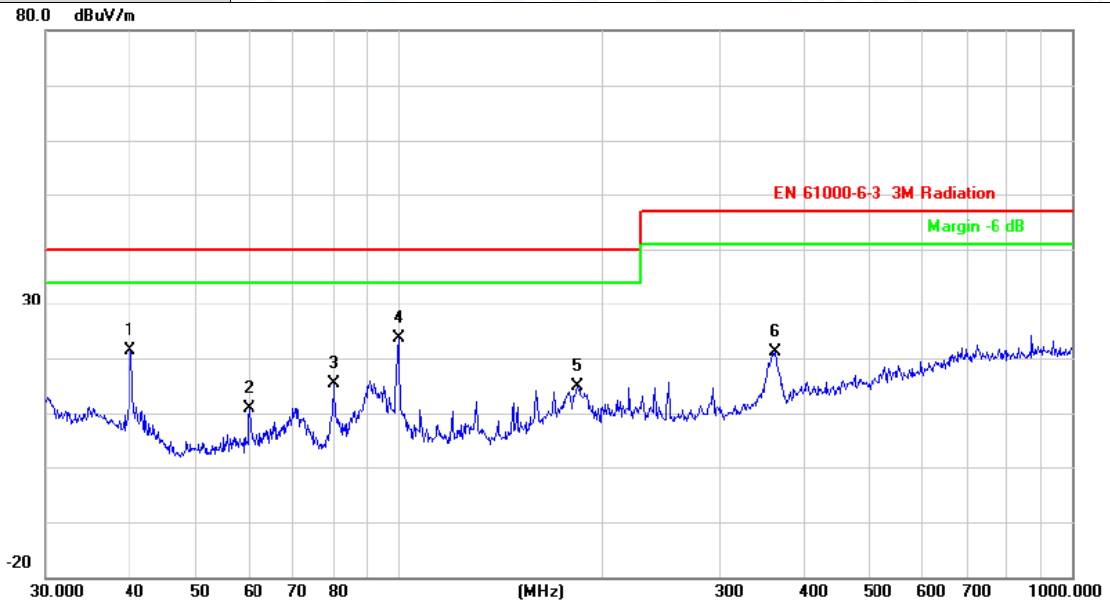

No.	Mk.	Freq. MHz	Reading Level dBuV	Correct Factor dB/m	Measure- ment dBuV/m	Limit dBuV/m	Over dB	Detector
1		39.9942	41.43	-20.16	21.27	40.00	-18.73	peak
2		60.0691	35.29	-24.51	10.78	40.00	-29.22	peak
3		80.0806	38.71	-23.28	15.43	40.00	-24.57	peak
4	*	100.2286	45.46	-21.82	23.64	40.00	-16.36	peak
5		184.4898	35.58	-20.73	14.85	40.00	-25.15	peak
6		362.9844	35.69	-14.53	21.16	47.00	-25.84	peak

Emission Level= Read Level+ Correct Factor

5. Electrostatic Discharge Immunity Test

5.1. Test Requirements

5.1.1. Test Standard

EN 61000-6-1: 2007 (EN 61000-4-2:2009)

5.1.2. Test Level

Level	Test Voltage Contact Discharge (kV)	Test Voltage Air Discharge (kV)
1	±2	±2
2	±4	±4
3	±6	±8
4	±8	±15
X	Special	Special

5.1.3. Performance criterion: **B**

5.2. Test Setup

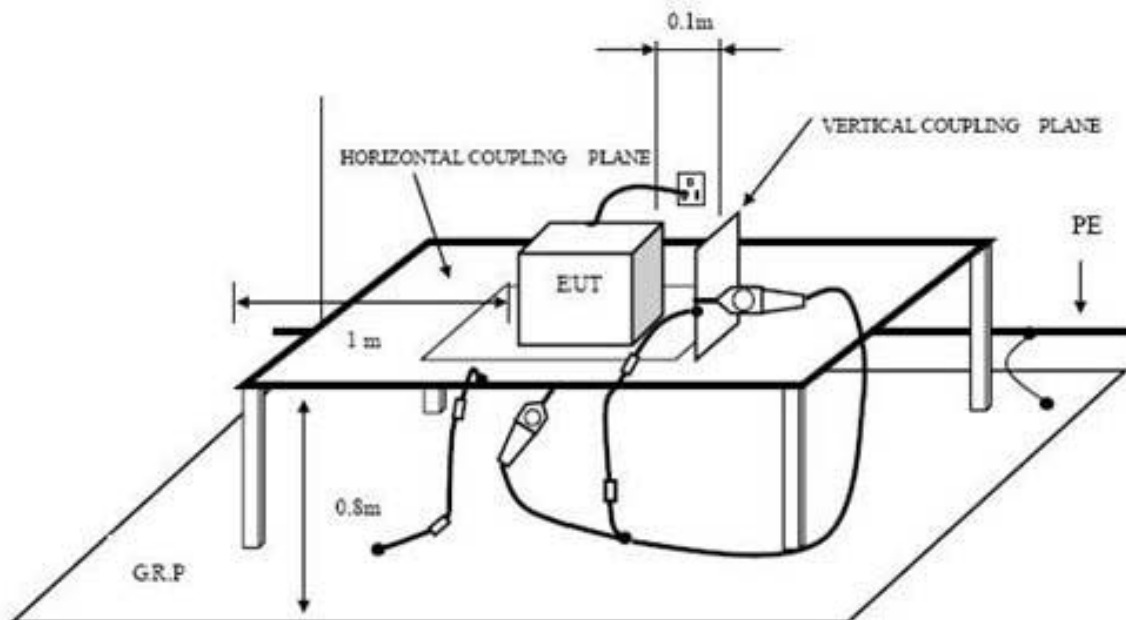

INDIRECT DISCHARGE SETUP

5.3. Test Procedure

5.3.1. Air Discharge:

This test is done on a non-conductive surface. The round discharge tip of the discharge electrode shall be approached as fast as possible to touch the EUT. After each discharge, the discharge electrode shall be removed from the EUT. The generator is then re-triggered for a new single discharge and repeated 10 times for each pre-selected test point. This procedure shall be repeated until all the air discharge completed.

5.3.2. Contact Discharge:

All the procedure shall be same as air discharge. Except that the tip of the discharge electrode shall touch the EUT before the discharge switch is operated.

5.3.3. Indirect discharge for horizontal coupling plane

At least 10 single discharges (in the most sensitive polarity) shall be applied at the front edge of each HCP opposite the center point of each unit (if applicable) of the EUT and 0.1m from the front of the EUT. The long axis of the discharge electrode shall be in the plane of the HCP and perpendicular to its front edge during the discharge.

5.3.4. Indirect discharge for vertical coupling plane

At least 10 single discharges (in the most sensitive polarity) shall be applied to the center of one vertical edge of the coupling plane. The coupling plane, of dimensions 0.5m X 0.5m, is placed parallel to, and positioned at a distance of 0.1m from the EUT. Discharges shall be applied to the coupling plane, with this plane in sufficient different positions that the four faces of the EUT are completely illuminated.

5.4. Test Data

Please refer to the following page.

Electrostatic Discharge Test Result

EUT	Lithium Iron Phosphate Battery	M/N	EV4850-T
Temperature	23°C	Humidity	53%
Power supply	DC 48V	Test Mode	Normal Mode
Criterion: B			
Air Discharge: $\pm 8\text{Kv}$ Contact Discharge: $\pm 4\text{Kv}$			
For each point positive 10 times and negative 10 times discharge.			
Location	Kind A-Air Discharge C-Contact Discharge		Result
Nonconductive Enclosure	A		PASS
Button	A		PASS
Port	A		PASS
HCP	C		PASS
VCP of front	C		PASS
VCP of rear	C		PASS
VCP of left	C		PASS
VCP of right	C		PASS

6. Radiated Electromagnetic Field Immunity Test

6.1. Test Requirements

6.1.1. Test Standard

EN 61000-6-1: 2007 (EN 61000-4-3:2006+A1:2008+A2:2010)

6.1.2. Test Level

Level	Field Strength V/m
1	1
2	3
3	10
X	Special

6.1.3. Performance criterion: A

6.2. Test Setup

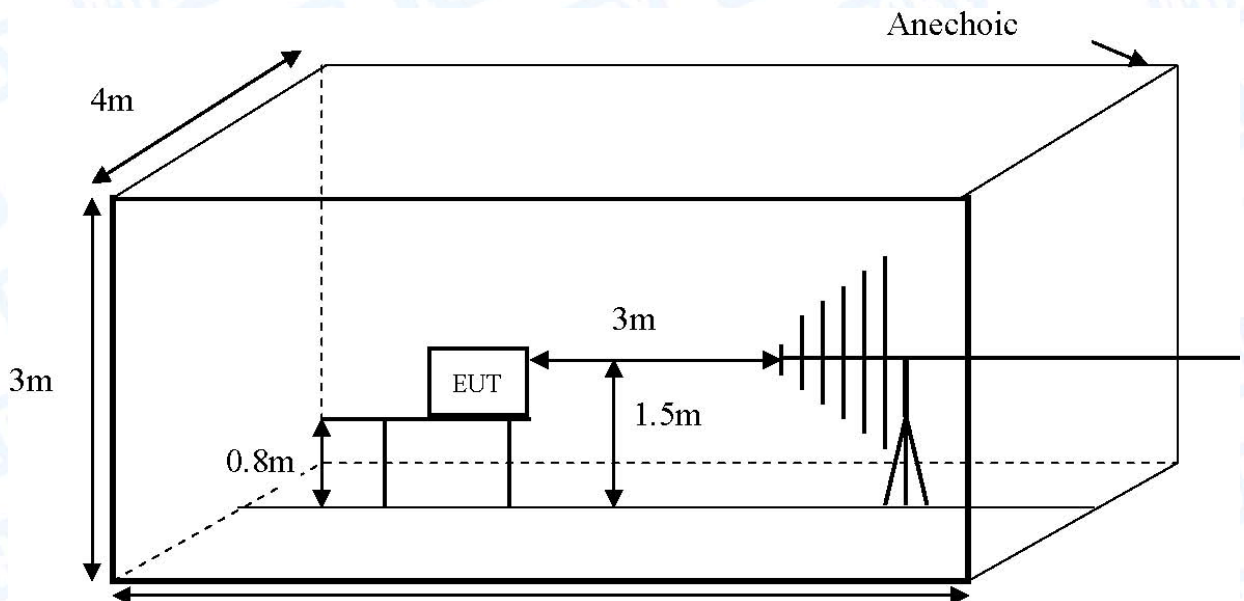

6.3. Test Procedure

The EUT are placed on a table, which is 0.8 meter high above the ground. The EUT is set 3 meters away from the transmitting antenna, which is mounted on an antenna tower. Both horizontal and vertical polarization of the antenna is set on test. Each of the four sides of the EUT must be faced this transmitting antenna and measured individually.

In order to judge the EUT performance, a camera is used to monitor its screen.

All the scanning conditions are as following:

Condition of Test	Remark
Fielded strength	3V/m (Severity Level 2)
Radiated signal	Modulated
Scanning frequency	80-1000MHz
Sweep time of radiated	0.0015 Decade/s
Dwell time	1 Sec.

6.4. Test Data

Please refer to the following page.

RF Field Strength Susceptibility Test Results

EUT	: <u>Lithium Iron Phosphate Battery</u>	M/N	: <u>EV4850-T</u>	
Temperature	: <u>23°C</u>	Humidity	: <u>53%</u>	
Power supply	: <u>DC 48V</u>	Test Mode	: <u>Normal Mode</u>	
Criterion: A				
Modulation: Unmodulated				
Pulse: AM 1KHz 80%				
	Frequency Range 1		Frequency Range 2	
	80~1000MHz		/	
	Horizontal	Vertical	Horizontal	Vertical
Front	PASS	PASS	/	/
Right	PASS	PASS	/	/
Rear	PASS	PASS	/	/
Left	PASS	PASS	/	/

7. Photographs - Constructional Details

Photo 1 Appearance of EUT



Photo 2 Appearance of EUT

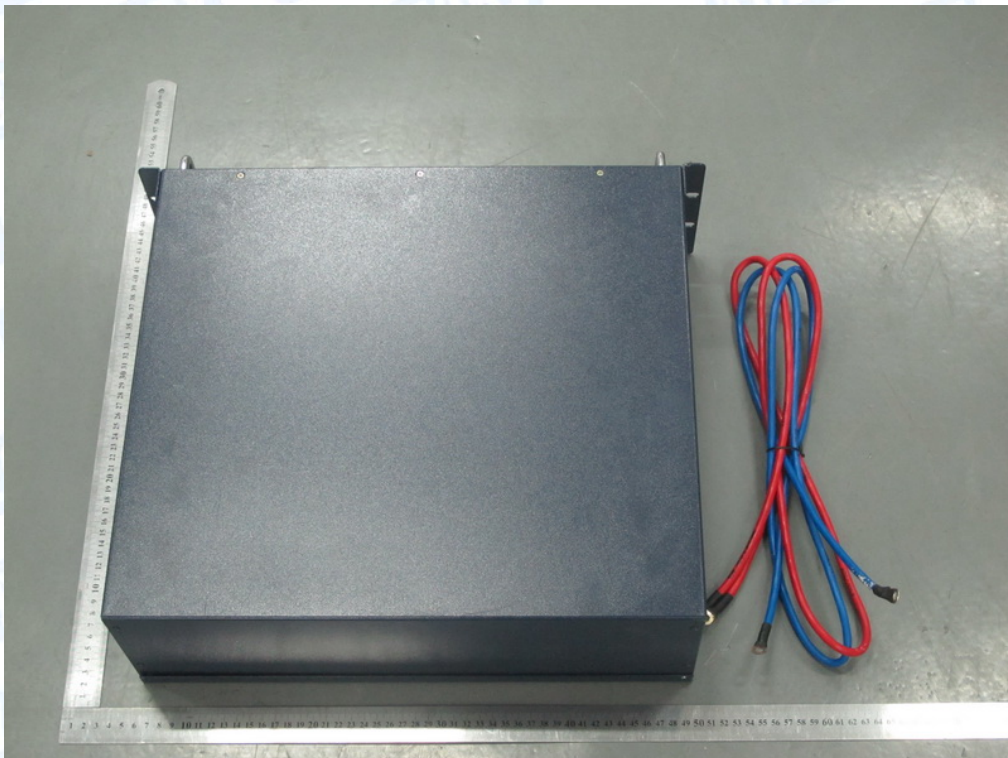
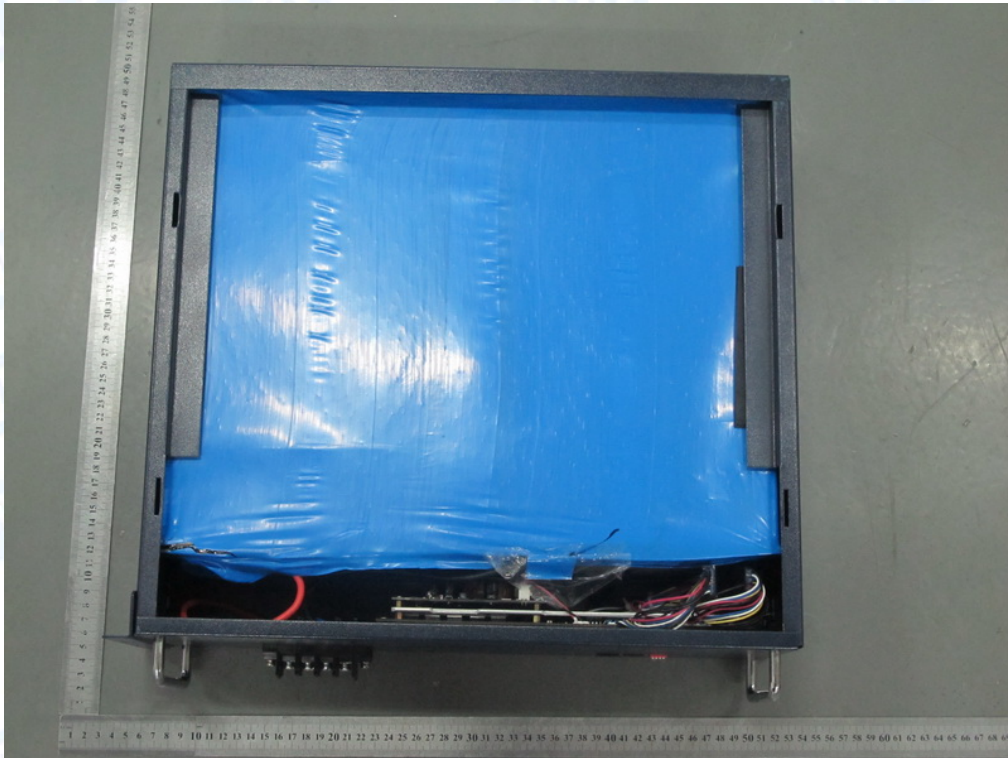

Photo 3 Internal of EUT



8. Photographs - Test Setup

Photo 1 Radiated Emission Test Setup

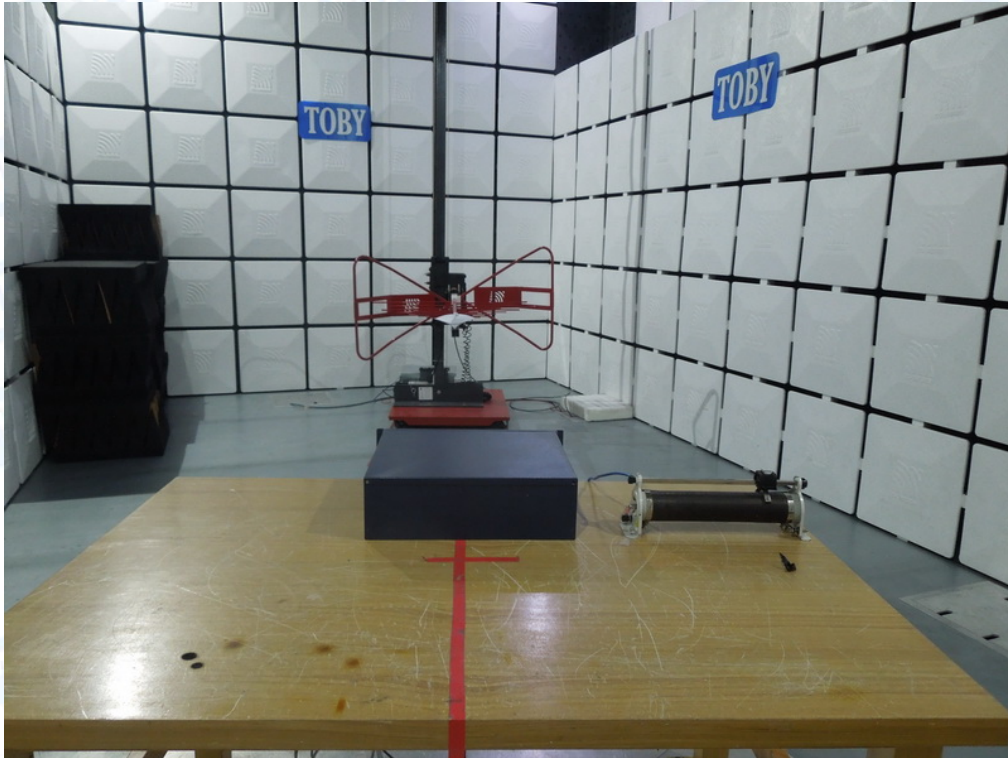

Photo 2 Electrostatic discharge Test Setup

